



**BMT**  
EXPORT

D 1000-1200 3L



SCARICO IDRAULICO TRILATERALE  
DESCHARGEMENT HYDRAULIQUE TRILATERAL  
THREE SIDES DISCHARGE  
DESCARGA HIDRAULICA GIRATORIA 180°

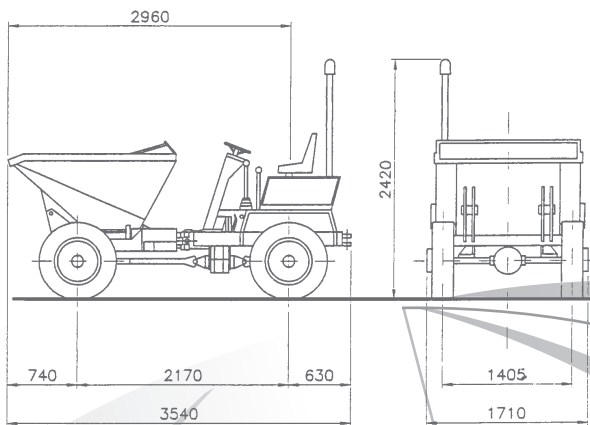

# D 1000-1200 3L

**CARATTERISTICHE TECNICHE**  
**DONNEES TECHNIQUES**  
**SPECIFICATIONS**  
**CARACTERISTICAS TECNICAS**

**CAPACITA' DELLA BENNA - CAPACITE' DE LA BENNE - SKIP CAPACITIES - CAPACIDAD DE LA TOLVA**

**A RASO**  
**A RAS**  
**STRUCK**  
**NIVEL DE AGUA**

**D 1000 3L**

**D 1200 3L**

**1.000 ltr.**

**1.200 ltr.**

**A COLMO**  
**COMBLEE**  
**HEAPED**  
**COLMADA**

**1.200 ltr.**

**1.500 ltr.**

**PORTATA**  
**PORTEE**  
**MAX PAYLOAD**  
**CARGA UTIL**

**2.500 Kg**

**3.000 Kg**

**PESO A VUOTO**  
**POIDS A VIDE**  
**UNLOADED WEIGHT**  
**PESO EN VACIO**

**1.390 Kg**

**1.700 Kg**

**MOTORE DIESEL / HATZ AVV. ELETTRICO**  
**MOTEUR DIESEL / HATZ DEMARRAGE ELECTRIQUE**  
**DIESEL ENGINE / HATZ ELECTRIC START**  
**MOTOR DIESEL / HATZ ARRANQUE ELECTRICO**

**2G40**

**2G40**

**POTENZA**  
**PUISSANCE**  
**POWER**  
**POTENCIA MOTOR**

**HP 23**

**HP 23**

**Nr. CILINDRI**  
**Nr. CYLINDRES**  
**Nr CYLINDERS**  
**Nr. CILINDROS**

**2**

**2**

**TRASMISSIONE**      **MECCANICA**  
**TRANSMISSION**      **MECANIQUE**  
**MECHANICAL**      **TRANSMISSION**  
**TRANSMISION**      **MECANICA MEDIANTE CARDAN**

**•**

**•**

**MARCE AVANTI / RETRO**  
**VITESSE AV/AR**  
**FORWARD / REVERSE GEARS**  
**VELOCIDADES ADELANTE / ATRAS**

**4/4**

**4/4**

**FRIZIONE MONODISCO A SECCO**  
**EMBAYAGE MONODISQUE A SEC**  
**SINGLE DRY PLATE CLUTCH**  
**EMBRAGUE MONODISCO EN SECO**

**•**

**•**

**VELOCITA' MAX**  
**VITESSE MAX**  
**MAX SPEED**  
**VELOCIDAD MAX**

**25 Km/h**

**25 Km/h**

**FRENI**      **IDRAULICI SULLE 4 RUOTE**  
**FREINS**      **HYDRAULIQUES SUR LES 4 ROUES**  
**BRAKES**      **4 WHEELS HYDRAULIC FOOTBRAKES**  
**FRENOS**      **HIDRAULICOS SOBRE LAS 4 RUEDAS**

**RUOTE MOTRICI**  
**ROUES MOTRICES**  
**WHEELS DRIVE**  
**RUEDAS MOTRICES**

**4**

**4**

**PNEUMATICI**  
**PNEUS**  
**TYRES**  
**NEUMATICOS**

**7,50 - 16**

**7,50 - 16**



**BMT**  
**EXPORT**

Made in Italy